



## AT-WIZ-7020A-4 Multi-Channel Intelligent RF Transceiver Modules

The AT-WIZ-7020 multi-channel transceiver modules are based on ABACOM Technologies' AT-XTR-7020 embedded transceiver modules and as such may serve as evaluation boards for the AT-XTR-7020 transceiver modules. In addition to offering an ideal evaluation platform for the AT-XTR-7020 transceiver modules, the AT-WIZ-7020 modules are complete standalone transceiver modules which may be interfaced to 5V level CMOS/TTL hosts, or the AT-WIZ-7020 may be interfaced to RS232 level serial data hosts such as the PC using the optional W232 RS232 interface cable. The AT-WIZ-7020 transceiver modules are transparent (virtual wire) devices and therefore do not require any special drivers and no special data formatting is required.

The AT-WIZ-7020 modules operate from a 4-10V power supply and include 5V to 3V level conversion interface for compatibility with 5V host devices. The I/O port is via a ten pin (2x5 pins) header connector and provides full user access to the AT-XTR-7020 RF transceiver I/O section. Jumpers are provided for data rate configuration. Data input and output is in standard serial data format.

The AT-WIZ-7020 multi channel transceiver modules include an embedded tuned loop antenna, thus eliminating the need for an external antenna.

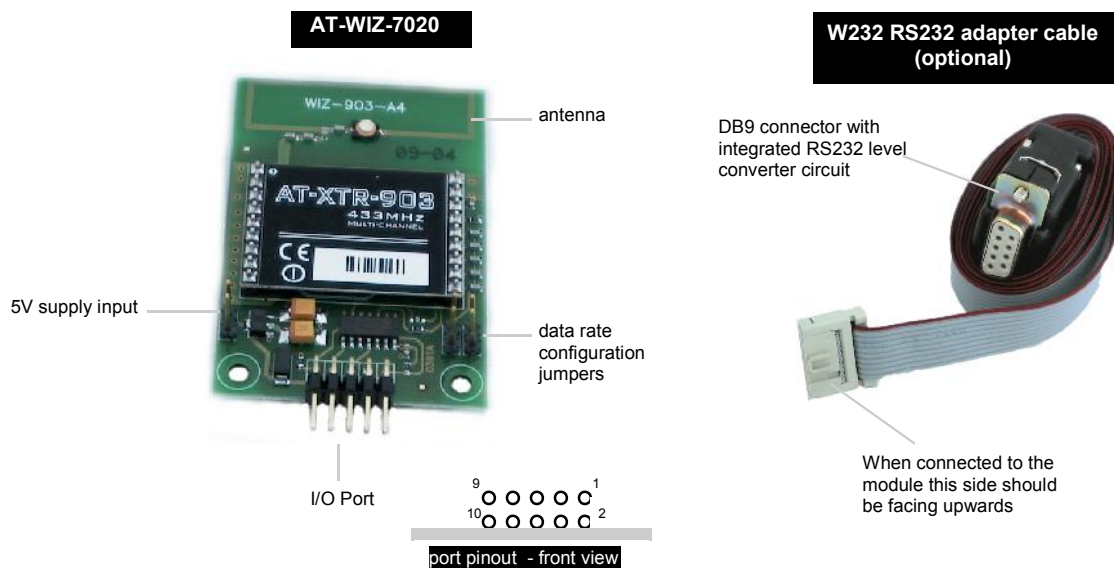

## Block Diagram

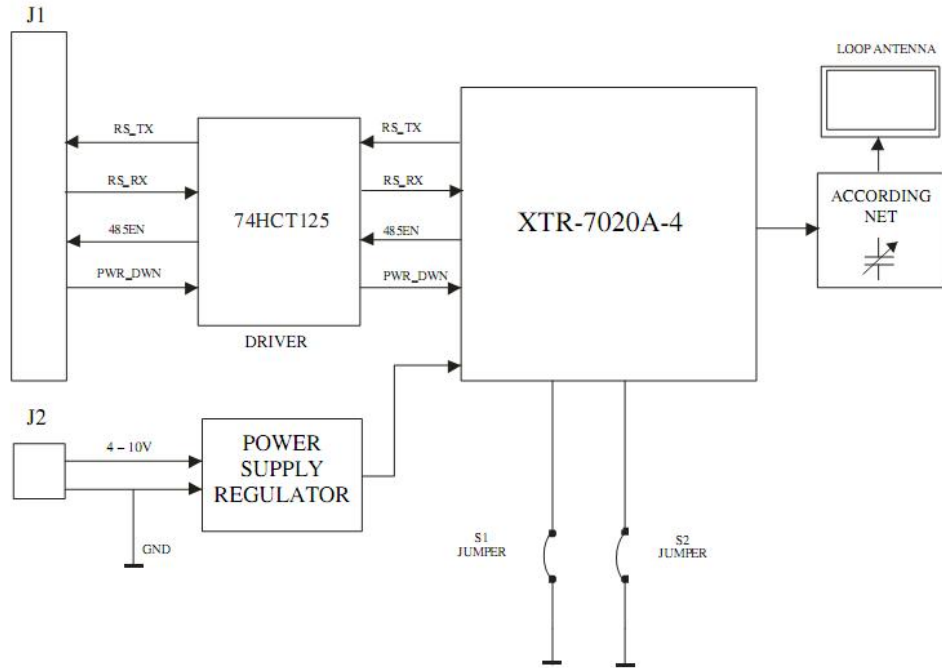

## Schematic Diagram

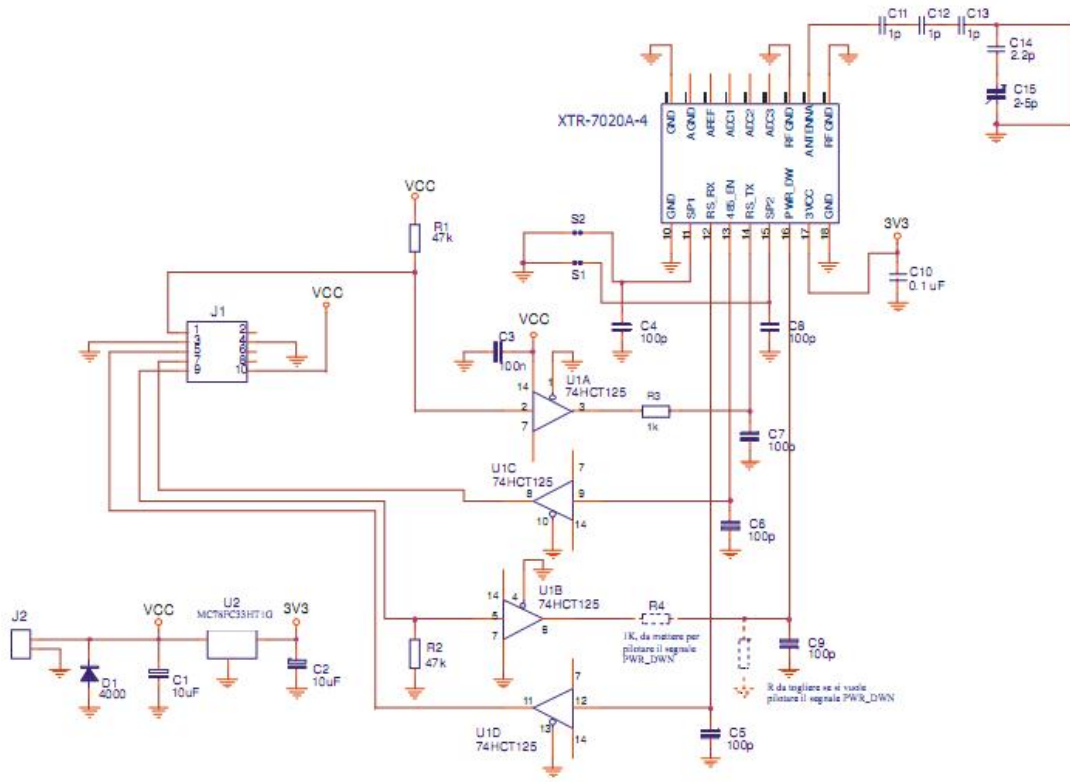

## Port Pin Designation

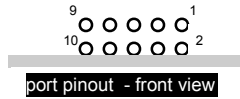

The AT-WIZ-7020 port pin numbering is from right to left when viewing the open ended pins from the front as in the figure above.

Pin 1	RS_RX
Pin 2,6,8	N.C.
Pin 3	GND
Pin 4	GND
Pin 5	RS_TX
Pin 7	485_EN
Pin 9	PWR_DWN (*)
Pin 10	Vcc (output to W232 RS232 interface adapter cable)

(\*) PWR\_DWN signal allows control of pin16 of the AT-XTR-7020A-4 RF module for low current SLEEP mode. The default mode is SLEEP not active. This may be changed if SLEEP mode is required, simply by adding a 1Kohm resistor R4 and by removing resistor R in parallel to capacitor C9. (refer to schematic diagram)

## Data Rate Configuration

The data rate configuration jumpers enable the user to select the desired data rates. A jumper installed is considered ON in the table below and an uninstalled jumper is considered OFF. For a description on the TEST mode and alternative (higher) data rates please refer to the AT-XTR-7020A-4 manual.

SP1	SP2	Configuration
OFF	OFF	9600
ON	OFF	19200
OFF	ON	38400
ON	ON	TEST Mode

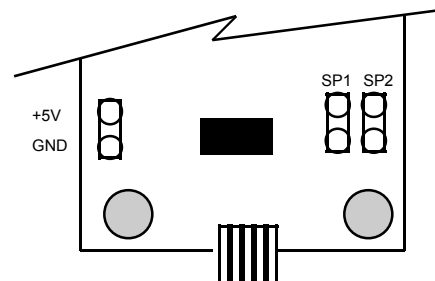

## PCB and Assembly Layout

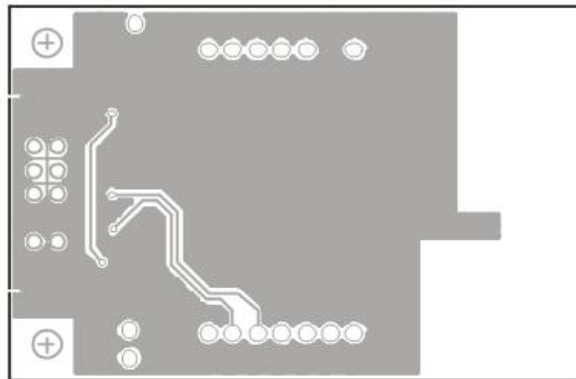
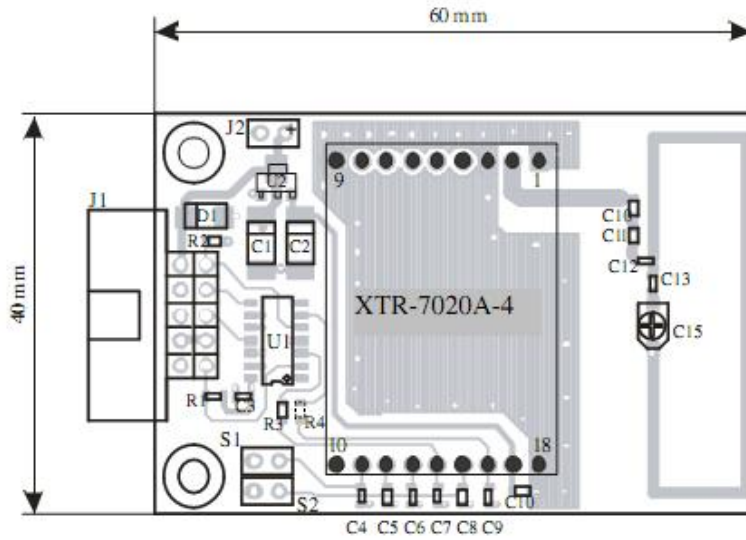

## Technical Characteristics

### Supply Voltage

Power to the module is via header J2 and is regulated to 3.3V by voltage regulator U2 (MC78FC33HT1G)

	Min.	Typ.	Max.	Unit
Supply voltage	4	5	10	V
Current consumption (RX, Vcc=5V)		36		mA
Current consumption (RX, Vcc=5V, with W232 adapter cable)		42		mA
Current consumption (TX max power, Vcc=5V)		45		mA
Current consumption (TX max power, Vcc=5V, with W232 adapter cable)		51		mA
Transmit Power (TX max power, Vcc=5V)		2		dBm

## Basic Setup and Operation

The AT-WIZ-7020 RF transceiver modules are very simple to setup and the RF link may be established in minutes. For the most basic applications, establishing a half duplex RF data link is a quick 4 step procedure:

- Configure the modules to the desired data rate
- Connect the RS-RX , RS\_TX and GND pins to the TTL/CMOS data host or to the RS232 level host with the optional W232 RS232 interface adapter cable
- Apply 5V Power to the power supply input pins
- Start Communications

The data connection to 5V CMOS/TTL hosts such as microcontrollers can be made directly to the AT-WIZ-7020 transceiver via the I/O port. Many applications require this type of connection at the one end of the link and an RS 232 connection at the other end. The RS232 level connection is simply accomplished with the optional W232 adapter cable. The block diagram below shows typical setup option with either RS232 level hosts or microcontroller hosts at each end of the link

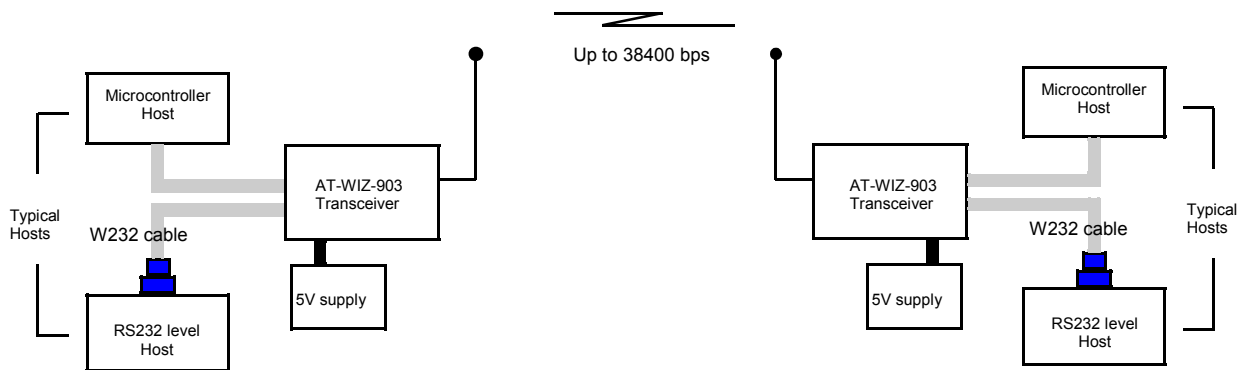

## Advanced Operation

With the integration of the AT-XTR-7020 RF transceiver section, the AT-WIZ-7020A-4 modules offer all of the advanced user programmable features and functions of the AT-XTR-7020 such as:

- Programmable RF Output Power
- Programmable Operating Channels
- TEST Mode
- Received Signal Strength Indication (RSSI)
- Power Down Mode

For details on these and other features please refer to the attached AT-XTR-7020 manual.