



AT-XTR-7020A-4 Multi-Channel Micro Embedded Transceiver Module

The AT-XTR-7020A-4 radio data transceiver represents a simple and economical solution to wireless data communications. The employment of an embedded microprocessor creates a transparent TTL RS-232 interface, and eliminates any need for data packetizing and encoding. The designer does not need to write complex software routines for the transmission management.

The input serial data rate (9600, 19200, 38400 bps or 9600, 57600, 115200 bps) is configured via two input lines SP1 and SP2. (The higher data rate group is configured by writing to register S5). Maximum packet length is 240 bytes.

The module is a multi-channel RF transceiver which features selection of **10 channels** between 433 and 434 MHz. Channel selection is very straightforward and takes place through simple AT commands. RF output power may be selected (from -8 dBm to +10 dBm) and monitoring of channel occupation is also performed through simple AT commands.

The device implements frequency modulation (GFSK) which guarantees a better noise immunity compared to amplitude modulation. Open air range of up to 200 m with omnidirectional antennas can be achieved.

The AT-XTR-7020A-4 has a small footprint measuring only 33 x 23 mm. Timing guarantees a maximum latency of only 21 ms between sending data and its reception. This minimal delay includes the necessary time for the device to switch from RX to TX and transmit a synchronization header. Supply voltage is 3V regulated and a power down mode is available, reducing current consumption to less than 10 μ A. Even in the power down state, the AT-XTR-7020A-4 retains valid interface levels with the user's host application.



Features

- **Transparent throughput of RS-232 data**
- **Also available on 900MHz and 868MHz**
- **No data encoding and no preamble required**
- **No data pre-formatting required**
- **Simple AT commands for channel selection, emitted power level and monitoring of channel occupation and signal strength**
- **HyperTerminal* compatible**
- **10 Selectable Operating Channels: 433-434 MHz model**
- **169 Selectable Operating Channels: 902- 928 MHz model (AT-XTR-7020A-9)**
- **Embedded microprocessor**
- **Small size (23x33x5mm)**
- **Emitted power: user adjustable to 10mW**
- **Supply voltage: 3V**
- **Range up to 600ft**

Typical Applications

- **Handheld Wireless**
- **Home automation**
- **Telemetry**
- **Access control**
- **Instruments monitoring**
- **Data acquisition**
- **POS terminals**
- **Robotics**

* Trademark registered by Hilgraeve

Pin Description

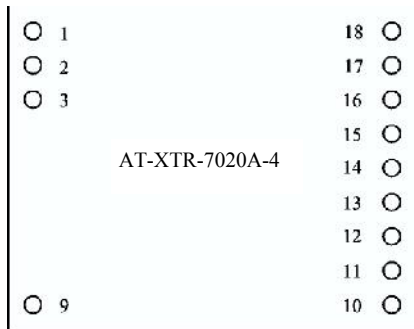

Pin Number	Pin Designation
1,3	RF GND
2	ANT
9,10,18	GND
11	SP1
12	RSRX
13	485EN
14	RSTX
15	SP2
16	PWRDN
17	Vcc
4,5,6,7,8	Not used

RF GND – pins 1,3

RF ground plane connection.

ANT – pin 2

Antenna terminal. 50Ω impedance.

Pins 4,5,6,7,8—not used

GND – pins 9,10,18

Ground (0V).

SP1, SP2 – pins 11,15

These pins configure the serial data rate. Table 1 indicates the configuration voltage levels of SP1 and SP2 for the three different data rates according to the register S5 setting.

Data Rate Configuration

SP1	SP2	I/O Data Rate	
		Register S5=0	Register S5=1
Vcc	Vcc	9600	9600
GND	Vcc	19200	57600
Vcc	GND	38400	115200
GND	GND	Test Mode pseudonoise	Test Mode Data packet

Table 1

A different degree of redundancy and protection is associated with the RF packet according to the selected speed. This means that slower data rate results in a higher level of reliability and/or longer communication distance.

RSRX – pin 12

Data output of the receiver in TTL RS-232 logic levels with 1 start bit (0V), 8 data bits and 1 stop bit (3V). Output is normally high (3V).



485EN – pin 13

Enable pin to control an external RS-485 transceiver .

RSTX – pin 14

Data input to the transmitter in TTL RS-232 logic levels with 1 start bit (0V), 8 data bits and 1 stop bit (3V). Input is normally high (3V).

PWRDN – pin 16

Enable pin to switch the power-saving feature ON or OFF . Applying 3V sets the module to Power Down mode, switching off all active circuitry and reducing consumption to less than 10 μ A. In the Power Down state, the logic levels of input/output data lines are still maintained at logic High levels (3V). Applying 0V to pin 16 configures the module for normal operating mode.

PWRDN	MODULE STATE
GND	ON
Vcc	OFF

Vcc – pin 17

Positive supply voltage (3V). Should be properly filtered and regulated.

Technical Characteristics

Absolute Limits	
Operating Temperature	-20 °C to +70 °C
Storage Temperature	-40 °C to +100 °C
Max. Supply Voltage	+6V
Input pin Voltage	-1.0 to Vcc + 0.3V
Output pin Voltage	-1.0 to Vcc + 0.3V

	Min.	Typ.	Max.	Units
DC values				
Supply Voltage	2.7	3.3	3.6	V
Current (rx mode)		26		mA
Current (tx mode @ -8 dBm)		20		mA
Current (tx mode @ 10 dBm)		31		mA
Current (stand-by mode)		8	10	µA
Input/output Logical 1 Level	0.7xVcc		Vcc	V
Input/output Logical 0 Level	0		0.3xVcc	V
RF				
Modulation Type		FSK		
Frequency Band		433.19 to 434.57		MHz
Rx Sensitivity		-100		dBm
Tx Max Power Output	-8		10	dBm
Performance				
Input Bit Rate ¹	9600, 19200, 38400, 57600, 115200			bps
Outdoor range		300		m
Available Channels			10	
Channel Spacing		153.6		KHz
Timing				
PWRDN to RX	20			ms
PWRDN to TX				ms
TX to RX			20	ms
RX to TX			20	ms
Default Values (NO programming)²				
Operating Channel		433.96		MHz
Tx Output Power		10		dBm

¹ Input signal consists of 1 start bit, 8 data bits and 1 stop bit, no parity.

² Default values are factory configured. May be changed with AT command programming.

Application

Integration of a powerful embedded microprocessor relieves the designer of the need to implement a synchronization protocol between the transmitting and receiving unit, thus significantly reducing the design cycle time. The AT-XTR-7020 RF transceiver module allows the transfer of serial data in RS232-TTL logic, as output from a microprocessor host or from a PC serial port (with electrical level conversion), without the need for any further coding. The radio transmission is completely transparent, allowing the radio transfer of data packets of any length* and with a latency of no longer than 20 ms between the data delivery and the actual reception. This time is required to "open" the communication connection. Thereafter, the data transfer occurs at the actual serial port speed (9600, 19200 or 38400 bps).

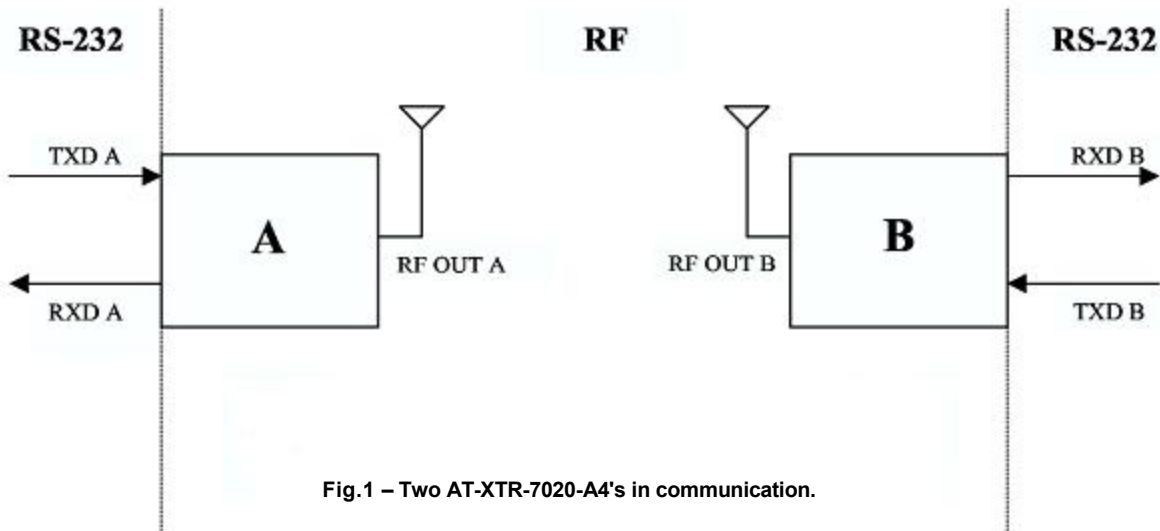
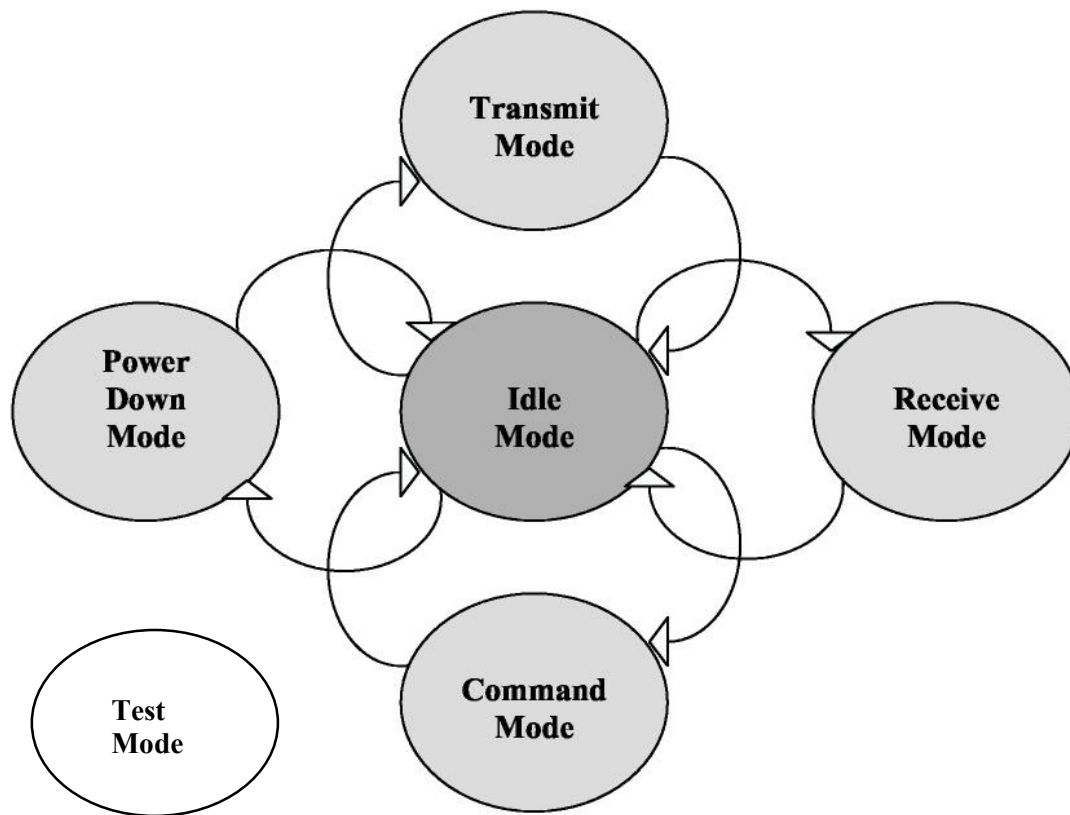

Fig.1 – Two AT-XTR-7020-A4's in communication.

AT-XTR-7020-A4 operation status may be summarized as follows:

- **Test Mode**
- **Idle Mode**
- **RF Transmit Mode**
- **RF Receive Mode**
- **Command mode**
- **Power Down mode**

The following pages discuss these modes in detail.



Test Mode

Test mode is entered into at power-up when SP1 and SP2 are at 0V (GND).

In this mode, and with register **S5=0** the carrier frequency is continuously modulated by a 20KHz pseudorandom data sequence.

With register **S5=1**, the test mode transmits a data packet of 4 incremental value digits.

The test mode may be put to good use when setting up the link and may be used in conjunction with the RSSI read command. (see command mode for details on reading the RSSI value). To exit the test mode, SP1 and SP2 must be reconfigured under a power off state.

Idle mode

This is the rest state of the transceiver, when initially powered. In this mode the transceiver will be "listening", waiting for either RF synchronization sequence or data presence on the serial line input. If any of the two conditions occur, the transceiver will exit the idle mode, and switch to the new relevant status.

Transmit mode

From the rest state in idle mode, the transceiver will automatically go to transmit mode as soon as it detects a start bit on the serial data input line (pin 14). The store and forward data transfer occurs as a paired sequence from the data input to the transmitter to data output at the receiving end:

- Unit A serial reception from host / Unit A RF transmission
- Unit B RF reception / Unit B serial transmission to host

The module automatically detects end of serial data by implementing a timeout function. The buffered data is then transmitted over the RF channel and error checked at the receiver and discarded if errors are present.

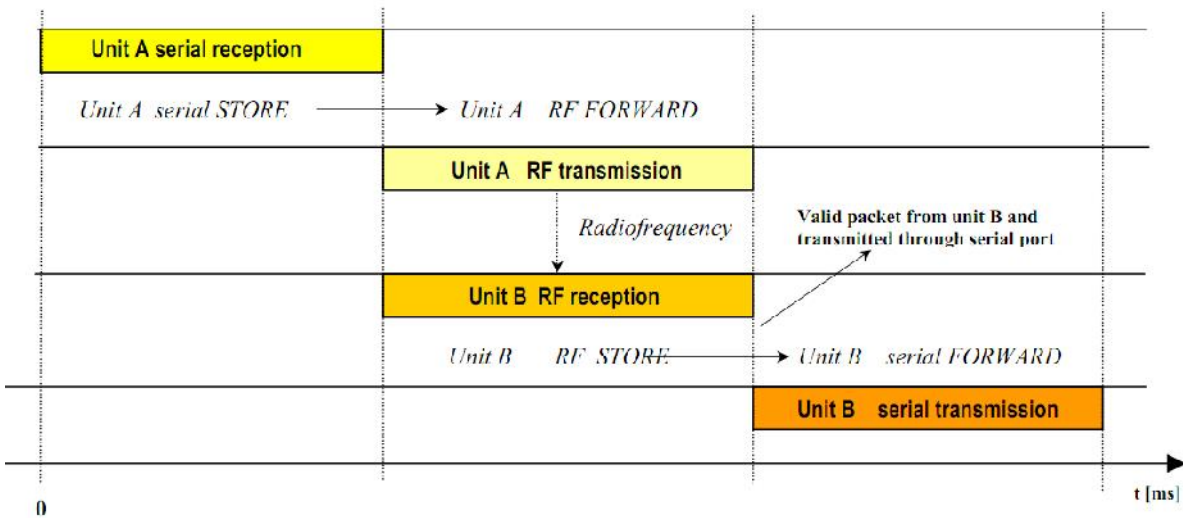

Fig. 3 – Store and Forward process

As shown in the above diagram, the time interval from the moment the data enters the modules port to the time the data is received by the remote module is a function of the number of bytes in the packet and the serial data rate.

For correct operation, data should not enter the modules port whilst the module is transmitting. Should this occur, the data would be lost. The same applies for module B ie data should not be sent to the module while it is receiving data.

Figure 4. Shows the sequence of transmitting a packet from A to B indicating at what time it is acceptable to input packet #2 to module A after reception of packet # 1 by module B to avoid overlapping of sending and receiving. It is necessary to allow a safety interval between sending consecutive packets which can be calculated based on the number of bytes of the first packet and the serial data rate using the following formula:

$$T_{RF} [ms] = K + 0.139 \cdot N_{byte}$$

with $K=4,21$ @9600bps, $K=3,35$ @19200bps, $K=3,1$ @38400 and 57600bps, $K=2,8$ @115200bps.

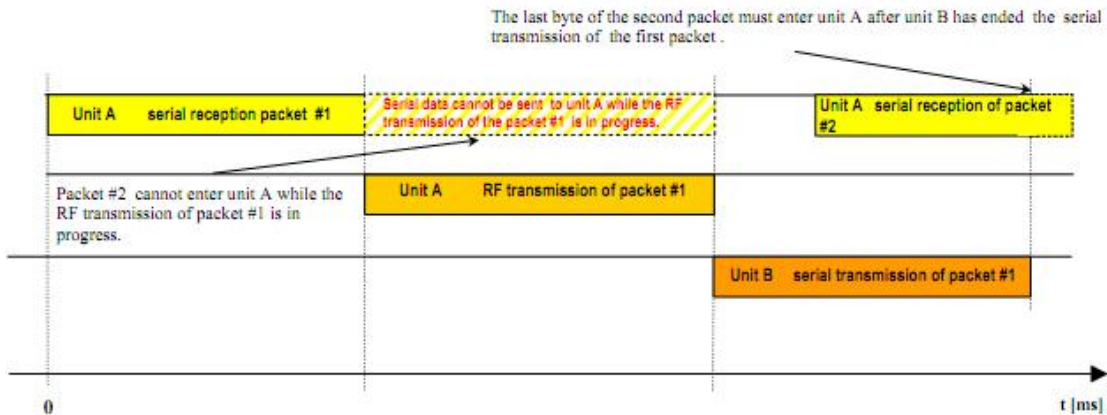

Fig. 4: Two data packets transmission

RF Receive mode

Transfer from Idle to Receive mode will occur as soon as the module recognizes the synchronization preamble on the incoming RF signal. At this point the transceiver will stay in Receive mode up to the reception of packet closing sequence.

Any data in input from the serial line will be discarded while the module is in Receive mode.

Command mode (AT-XTR-7020A-4 module programming)

Command mode allows the designer /user to configure the main parameters which change the module's operating conditions, such as selecting a new operating frequency channel or setting the RF output power to desired value. This allows a high degree of flexibility to customize the AT-XTR-7020A-4 transceiver module for a specific application.

Programming is carried out via simple AT commands. To enter the Command mode from Idle mode, the following data string must be sent via serial RSTX line to the module:

- 3 consecutive ASCII plus characters (+++) without pauses

Within 35 ms, the module will respond with **OK<CR><LF>** string to confirm it is in Command mode. (<CR> represents 'Carriage Return') (<LF> represents 'Line Feed')

Programming information is stored in 16 available registers (from 1 to 16). Some of these are available only for read operations, while others are available for read/write operations.

The syntax to read a value stored in a register is as follows:

ATSx<CR><LF> (x= register 1, ..., 16)

Assuming that the command was issued correctly, the answer to this command is the value of the contents of the register. For a command issued with errors, the following answer is returned:

ERROR<CR><LF>

To change the value of parameter in a register, the following syntax is used:

ATSx=Y<CR><LF> (x= 1, ..., 16) , Y= value to be inserted

A command issued correctly will receive **OK<CR><LF>** response. If the command contained a syntax error or if the value that was entered to be written is an unacceptable parameter for that register, an **ERROR<CR><LF>** response will be received.

All the values written into registers are volatile and will be lost when the module is powered OFF, unless they were previously saved into the EEPROM memory available in the embedded microprocessor. In this case, the modified values will be non-volatile and will be retained even if the module's power supply is cycled.

The command for non-volatile saving of ALL the values in register is:

ATWR<CR><LF>

To exit Command Mode and return the transceiver to normal operating , the following command is issued:

ATCC<CR><LF>

When in Command mode, it is possible to include multiple commands in a single command line by separating each command by a comma (,) operator. With following command line, for example, register 3 is set to value 2, the change is permanently saved and the Command Mode is exited:

**Example: AT+3=2,WR,CC <CR><LF>
OK<CR><LF>**

As shown in the above example, the prefix -AT- is only used once in the beginning of the command of line and not required for the following commands which are separated with the comma operator.

Command chaining is possible only for write operations. If used in read operations, an "ERROR" message will be returned as in the following example:

**Example: ats1,cc <CR><LF>
ERROR <CR><LF>**

Commands are not case sensitive, so either uppercase or lowercase characters may be used.

Refer to **Appendix A**. for details on register values and possible configurations.

Power Down Mode

Setting pin 16 (PWRDN) high (+3V) configures the transceiver to power saving mode, limiting its current consumption to less than 10 μ A. Whilst in Power Down the transceiver is not in a condition to receive or transmit but will continue to maintain the correct logic levels with the externally interfaced devices, for example, the received data line (RXD) will be kept HIGH (+3V) associated with a STOP bit. To bring the transceiver back to an operating state (Idle Mode), pin 16 must be taken low (0V).

Applications

Fig.5 shows a typical AT-XTR-7020A-4 application, with the transceiver connected to a microprocessor that, in addition to data reception and transmission on the input and output lines (TXD & RXD), is also controlling two lines dedicated to serial interface speed selection (SP1 & SP2) plus the PWRDN line.

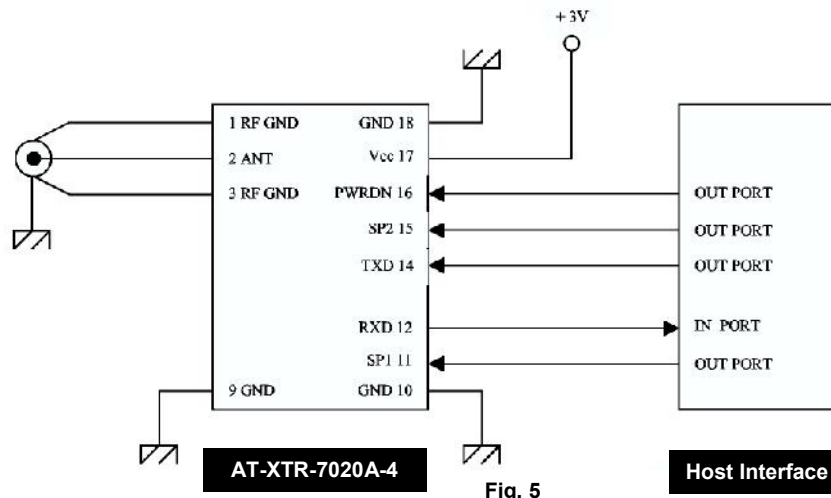

Fig. 5

Fig.6, shows a typical connection between the AT-XTR-7020A-4 module and PC serial port. The integrated circuit between the transceiver and the RS232 port is only used to convert the electrical level voltages between RS-232 and TTL logic. (eg. MAX 232)

With the use of the RTS line (pin 7 of DB9 connector) it is possible to drive the PWRDN line, while the serial data speed selection is set to 19200 bps.

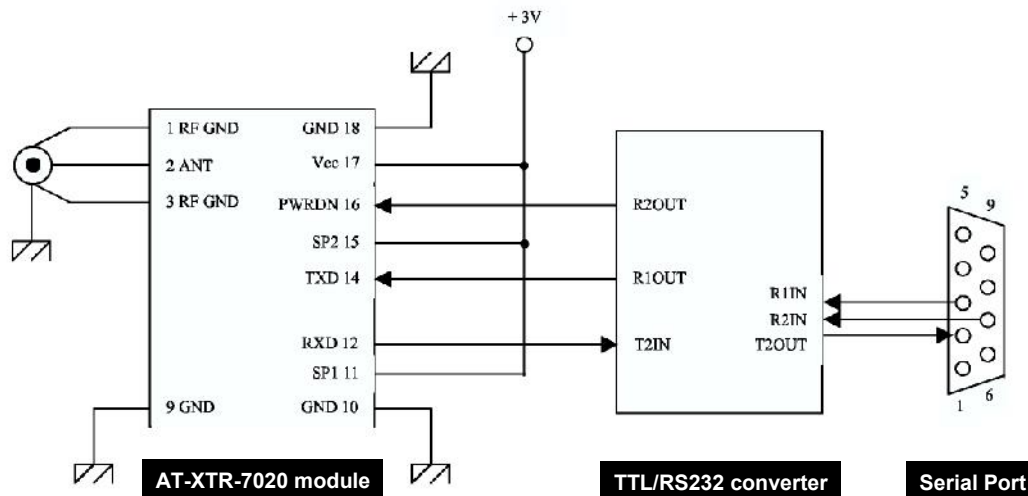

Fig.6 – Example connection of XTR-7020A-4 and RS-232 serial port at 9600 bps.

Application Suggestions

The following suggestions serve as guidelines in the final design and should not be considered as essential for prototyping purposes.

GROUND Circuit

- The module should be surrounded with ground plane. The circuit is best designed on double sided through plated PCB, with the ground planes on each side connected with vias (pass-through) at least every 15 mm.
- Ground plane must be present around the antenna connection

50 Ω Transmission lines (connection between pin 2 and Antenna)

- Should be as short as possible
- Trace width of 1.8 mm for FR4 PCB substrates with 1 mm cross section and 2.9 mm for substrates with 1.6 mm cross section. Trace distance from surrounding ground plane should be more than 1 mm (2 mm is better).
- The bottom side of the PCB should have a relatively large ground plane area.

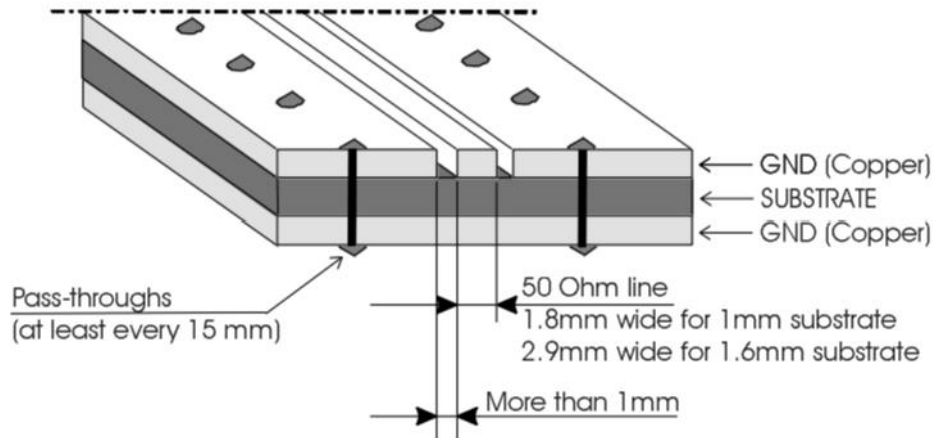

Antenna connection

- Can be used to directly connect a radiating stylus (165 mm straight wire)
- Can be used to connect the central conductor of a coaxial cable to an off-board remote antenna. The cable's outer braid must be connected to GND near the antenna connection.

Antenna

- An antenna must be connected to the transceiver antenna pin. A 16.5 cm whip antenna of 1mm diameter copper or brass may be used or 22 guage solid core insulated wire also works well. The body of the antenna should be as straight as possible and should be kept away from any other circuits or metal surface areas (at least 5 cm clearance is suggested)
- Antenna can be oriented either vertically or horizontally, with an abundant ground area around the connection feed point.

Note: ABACOM Technologies, Inc. offers a variety of manufactured antenna suitable for use with the AT-XTR-903 modules.

Other components

- Position the RF module as far from other circuit components as possible (min. 5 mm)
- Keep microprocessor clock circuits as far away as possible. Apply GND shields.
- Do not install components around the 50 Ω line (s). Keep at least 10 mm clearance.
- If a PCB antenna is implemented, the area allocated for the antenna should not have any other circuits in close proximity .
- If the antenna connection is via coaxial cable, then other components may be placed around the connection point but approximately 5mm clearance away from the connection point should be given.

Mechanical dimensions

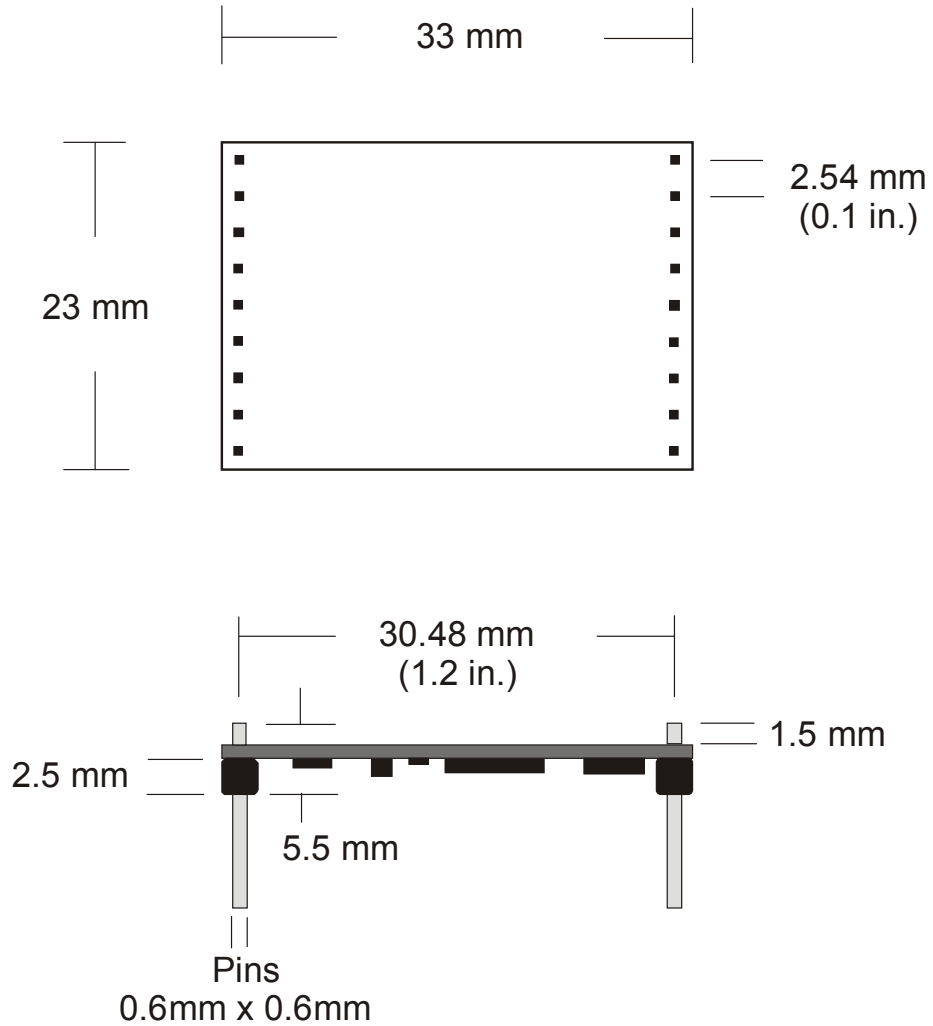

Appendix A – Register Programming

Different operating characteristics of the transceiver, such as RF channel selection, RF emitted power, etc..., can be programmed by the user through setting special parameters in 16 available registers.

The following information provides the meaning and programming possibilities for each register.

The current AT-XTR-7020A-4 transceiver module implements 4 out of 16 registers - registers 1,2,3 and 16. Only these registers will be described, the remaining registers are reserved for possible future enhancements.

Register 1 - Frequency Band

This register is READ ONLY and will supply information relating to the module's operating RF band. The AT-XTR-7020A transceiver modules are available in three different models, 433MHz, 868MHz and 915MHz, identified with suffixes -4, -8, and -9 respectively.

Command	Values	Read (R) / Write (W)
ATS1	0 =433-434 MHz	R
	1 =868-870 MHz	
	2 =902-928 MHz	

Example 1: Reading the operational band of the module

```
+++  
OK<CR><LF>  
ATS1<CR><LF>  
0                (0 = 433-434MHz band)
```

Example 2:

```
+++  
OK<CR><LF>  
ATS1=2<CR><LF>  
NO ACCESS<CR><LF>
```

Syntax Error: This register is available for Read only!

Register 2 – RF CHANNEL

This register is available for read and write operations. It allows to get feed backs of the RF frequency (channel) setting for both receiving and transmitting circuits. Makes it possible to "write" a different frequency (channel).

Command	Values	Read (R)/ Write (W)
ATS2	0 = 433.19 MHz 1 = 433.34 MHz 2 = 433.50 MHz 3 = 433.65 MHz 4 = 433.80 MHz 5 = 433.96 MHz 6 = 434.11 MHz 7 = 434.27 MHz 8 = 434.42 MHz 9 = 434.57 MHz	R/W

Example 1: Reading the configured RF channel (433,5 MHz)

```
+++  
OK<CR><LF>  
ATS2<CR><LF>  
2
```

Example 2: Selecting channel 8 as the operating frequency (434,42 MHz)

```
+++  
OK<CR><LF>  
ATS2=8<CR><LF>  
OK<CR>
```

Register 3 – EMITTED RF POWER

This register is available for read and write operations. With the read command, feedback is given about the RF output power emitted from the module's transmitter section. The write command and enables the user to configure the transmitter section for the preferred RF output power.

Command	Values	Read (R)/ Write (W)
ATS3	0 = - 8 dBm 1 = - 2 dBm 2 = + 4 dBm 3=+10 dBm	R/W

Example 1: Reading the configured RF output power (-2 dBm)

```
+++  
OK<CR><LF>  
ATS3<CR><LF>  
1
```

Example 2: Setting RF output power to +10 dBm

```
+++  
OK<CR><LF>  
ATS3=3<CR><LF>  
OK<CR><LF>
```

Register 16 – RSSI (Received Strength Signal Indicator)

The register is read only and will supply a numeric value proportional to the RF Field Strength sensed from the receiving circuitry. The range of possible values returned from the register are 0 through 9. Reading register 16 starts a process of analysis of the RF channel that the module is programmed to operate on. This routine has a fixed duration of 200ms and the analysis result is given after this period. The analysis period should be allowed to run its course without interruption through issuing another command. The signal strength command is useful for determining possible channel occupation or for setting up the link in conjunction with the TEST mode.

Command	Values	Read (R)/ Write (W)
ATS16	0 = Minimum Field Strength 1 2 3 4 5 6 7 8 9 = Maximum Field Strength	R

Example 1: Reading Field Strength (strong received signal)

```
+++  
OK<CR><LF>  
ATS16<CR><LF>  
9
```

Example 2: Reading Field Strength (very weak or no received signal)

```
+++  
OK<CR><LF>  
ATS16<CR><LF>  
0
```

Example 3: Syntax Error: register is read only!

```
+++  
OK<CR><LF>  
ATS16=3<CR><LF>  
ERROR<CR><LF>
```

Disclaimer:

Technical specifications are subject to change without notice. Whilst every effort has been made to ensure the accuracy of the information contained in this document, ABACOM Technologies Inc. does not assume responsibility for any errors or omissions that may exist. ABACOM Technologies Inc. does not assume responsibility for any damage caused through use or misuse of their products and the onus lies entirely with the end user in determining the suitability of and use of the product for any particular application. ABACOM Technologies Inc. products are not recommended for applications where human life may be at risk.