



HAT-12D4L Latched o/p, 4 bits data

This chip emulates the Holtek decoding protocol. The decoder waits for two transmissions with the proper format, then decodes the incoming data and latches it to the outputs. The Valid Transmission (11) pin goes high at the same time the data is sent to the outputs.

The four bits of data that are received are the last four bits received. The first eight bits contain the address. The address of the decoder can be set by bringing the Learn (6) pin high for approximately 3.5 seconds. After 3.5 seconds Learn IND (7) goes low; which can be used to sink up to 15mA to drive an LED, and the first valid transmission received sets the address. This address is stored in EEPROM memory and will be retrieved on power up. If being used with a Holtek HT-12E encoder, its oscillator should be configured with a 680k resistor.

Features

- Operating voltage: 4.5V-5.5V
- 8 Bit address
- 4 Data outputs which are latched
- Active high valid transmission pin
- Very few external components (10MHz crystal and two 22pF capacitors)

Typical Applications

- Security systems
- Remote monitoring
- Remote control
- Smoke/Fire alarm systems

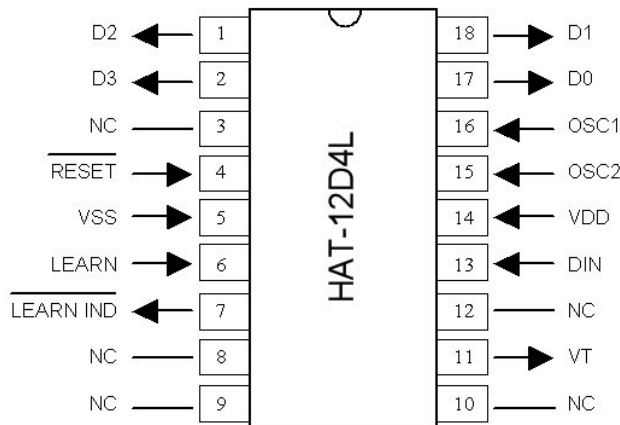
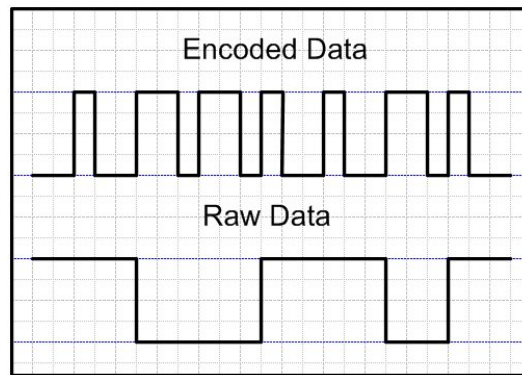

Pinouts

PIN	Function	Signal Direction
1	D2	Output
2	D3	Output
3	NC	N/A
4	RESET	Input
5	VSS	Input
6	LEARN	Input
7	LEARN IND	Output
8	NC	N/A
9	NC	N/A
10	NC	N/A
11	VT	Output
12	NC	N/A
13	DIN	Input
14	VDD	Input
15	OSC2	Input
16	OSC1	Input
17	D0	Output
18	D1	Output

Pin Descriptions

D0—D3: The received data is latched to these outputs. Active high, can sink/source up to 15mA.

RESET: Active low. Tie high for normal operation.

VSS: Ground reference.

LEARN: When pulled high for 3.5 seconds, the next valid transmission received sets the address of the decoder.

LEARN IND: When the chip goes into learn mode (pin 6 has been high for 3.5s) this pin goes low. Can be used to sink up to 15mA to drive an LED indicator.

VT: Upon reception of a valid transmission, this pin goes high until 50ms after the last proper data packet has been received.

DIN: Encoded data input (from the receiver). Encoded data should be encoded according to the Holtek HT-12E protocol. With respect to the HT-12E, A0 to A7 are decoded as the address and D0 to D3 are the four data bits. If used with a Holtek HT-12E encoder, its oscillator should be configured with a 680k resistor.

VDD: Positive voltage reference.

OSC1—OSC2: Oscillator input. Each should have a 22pF capacitor to ground and a 10MHz crystal across the pins. See the figure below.

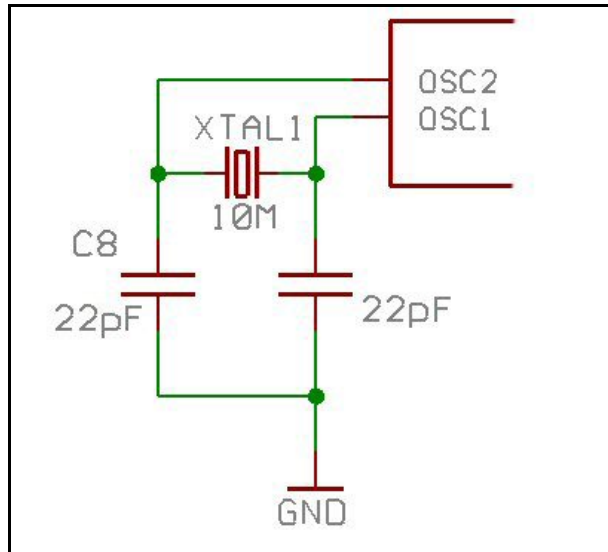

Oscillator configuration.

Disclaimer:

Technical specifications are subject to change without notice. Whilst every effort has been made to ensure the accuracy of the information contained in this document, ABACOM Technologies Inc. does not assume responsibility for any errors or omissions that may exist. ABACOM Technologies Inc. does not assume responsibility for any damage caused through use or misuse of their products and the onus lies entirely with the end user in determining the suitability of and use of the product for any particular application. ABACOM Technologies Inc. products are not recommended for applications where human life may be at risk.